

ELECTRICAL STEEL





Electrical steels are distinguished by their excellent electro-magnetic properties. There are two categories: grain-oriented electrical steel and non-oriented electrical steel. Today, as the need to reduce energy usage and protect the becoming more and more important, demand for high quality electrical steel is also growing. POSCO produces 1 million tons of high quality electrical steel each year.

ELECTRICAL STEEL

Contents

Pohang & Gwangyang Steelworks	04
Manufacturing Processes & Equipment	06
Specification	08
Main Application	09
Grain-oriented Electrical Steel	10
Non-oriented Electrical Steel	16
Surface Insulation	27
Stress Relief Annealing	28
Surface Condensation in Relation to Humidity and Temperature	29
Relations Among Weight, Outside Diameter & Width of Coil	30
Major International Standards	31
Unit Conversion Tables, the International System of Units (SI)	33
Packaging & Marking	34



Upon completion of its first-phase manufacturing facility in 1973, Pohang Steelworks, Korea's first integrated steel mill, was finally completed after 4 stages of construction at Young-il Bay in February 1981.

POSCO is capable of producing and processing a variety of carbon steels and stainless steels. The company's global competitiveness was further enhanced when we opened the world's first FINEX commercialization facility in May 2007.

Main products hot-rolled steel, plate, cold-rolled steel, wire rod, electrical steel, stainless steel, API steel, etc.

Crude steel production 16.185 million tons (as of 2013)



Gwangyang Steelworks is the world's largest integrated steel mill. It features an optimal plant layout with carbon steel processing and high-mill processing capabilities, producing automotive steel, high-strength hot rolled steel, high-quality API steel, and thick plates among other products.

With the goal of specializing in the manufacturing of the world's best automotive steels, Gwangyang Steelworks focuses on enhancing its competitive edge.

Main products hot-rolled steel, plate, cold-rolled steel, car steel, API steel, etc.

Crude steel production 20.231 million tons (as of 2013)

The POSCO Quality

Ultra-High Quality Products Which Touch the Customer's Soul

- **Customer Inside:** We create the best value for customers by keeping their needs foremost.
- **Basic Inside:** We focus on fundamentals and principles, eliminating deviation and waste.
- **Synergy Inside:** We seek to grow alongside our supplier chain through trust and communications.



Manufacturing Processes & Equipment

In order to deliver high quality products meeting our customer's requirements, POSCO is equipped with the latest fully-automated computer-controlled, cutting-edge facilities and technologies.

Grain-oriented electrical steel

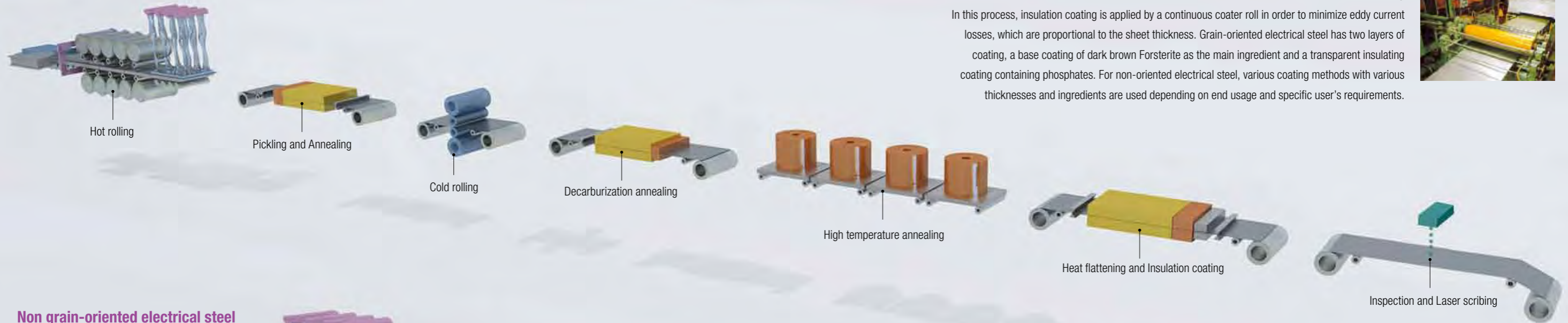

Annealing

Annealing is a process in which cold rolled structures are converted to a recrystallized structure through heat treatment. For grain-oriented electrical steel, two different annealing methods are available: decarbonization annealing and high temperature annealing. Decarbonization annealing removes excess carbon from the steel and apply an MgO coating. High temperature annealing produces secondary recrystallized structures having superior magnetic properties.



Insulation Coating

In this process, insulation coating is applied by a continuous coater roll in order to minimize eddy current losses, which are proportional to the sheet thickness. Grain-oriented electrical steel has two layers of coating, a base coating of dark brown Forsterite as the main ingredient and a transparent insulating coating containing phosphates. For non-oriented electrical steel, various coating methods with various thicknesses and ingredients are used depending on end usage and specific user's requirements.



Non grain-oriented electrical steel

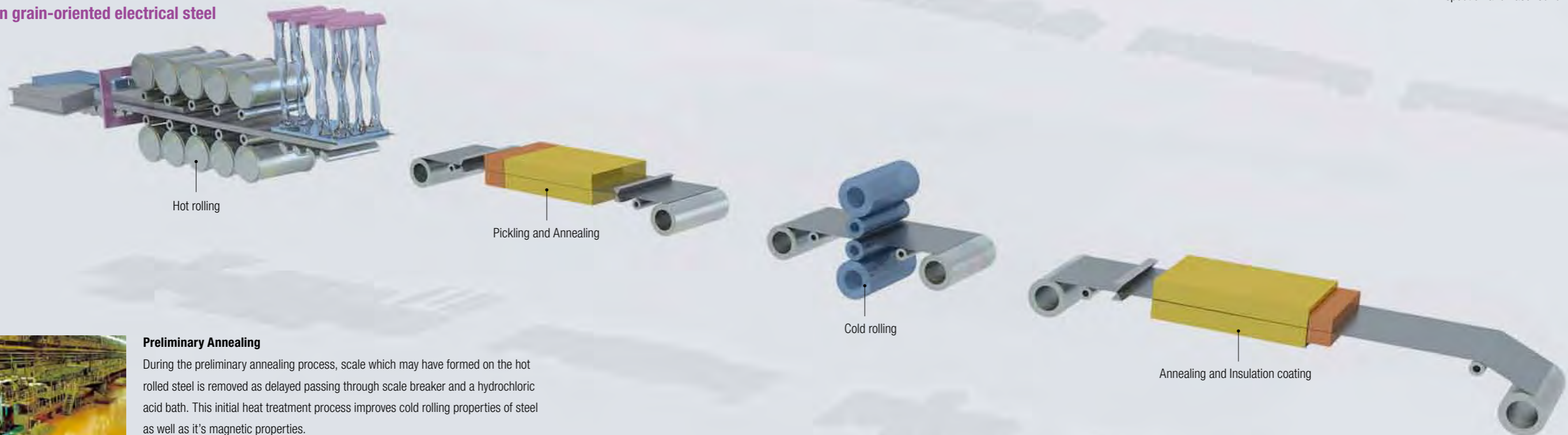

Preliminary Annealing

During the preliminary annealing process, scale which may have formed on the hot rolled steel is removed as delayed passing through scale breaker and a hydrochloric acid bath. This initial heat treatment process improves cold rolling properties of steel as well as its magnetic properties.



Cold Rolling

In order to obtain specific thickness and material properties, reduction ratio of 40–90% is applied normally. Rolling and edge trimming machines are automatically controlled to obtain uniform thickness and width.

Specification

	Grain-Oriented			Non-Oriented						
	PHD-Core	PH-Core	PG-Core	PN-Core			PNM-Core	PNA-Core	PNS-Core	PNF-Core
				PN210-400	PN440-700	PN800-1300				
Rotating Machines	Large rotating machine			●					●	
	Medium rotating machine			●	●			●	●	
	General use AC motor				●	●		●		●
	Hermetically sealed motor			●	●	●		●	●	
	Small motor & Intermittent Service AC motor			●					●	●
Static Machines	Large power transformer	●	●	●						
	Medium & small power transformer	●	●	●	●					
	Distribution transformer	●	●	●						
	Reactor & magnetic amplifier	●	●	●	●					
	Audio transformer	●	●	●	●	●	●	●		
	Current & potential transformer	●	●	●	●					
	Ballast				●	●	●	●		
	Welding transformer					●				
Magnetic switch core							●			

Main Application

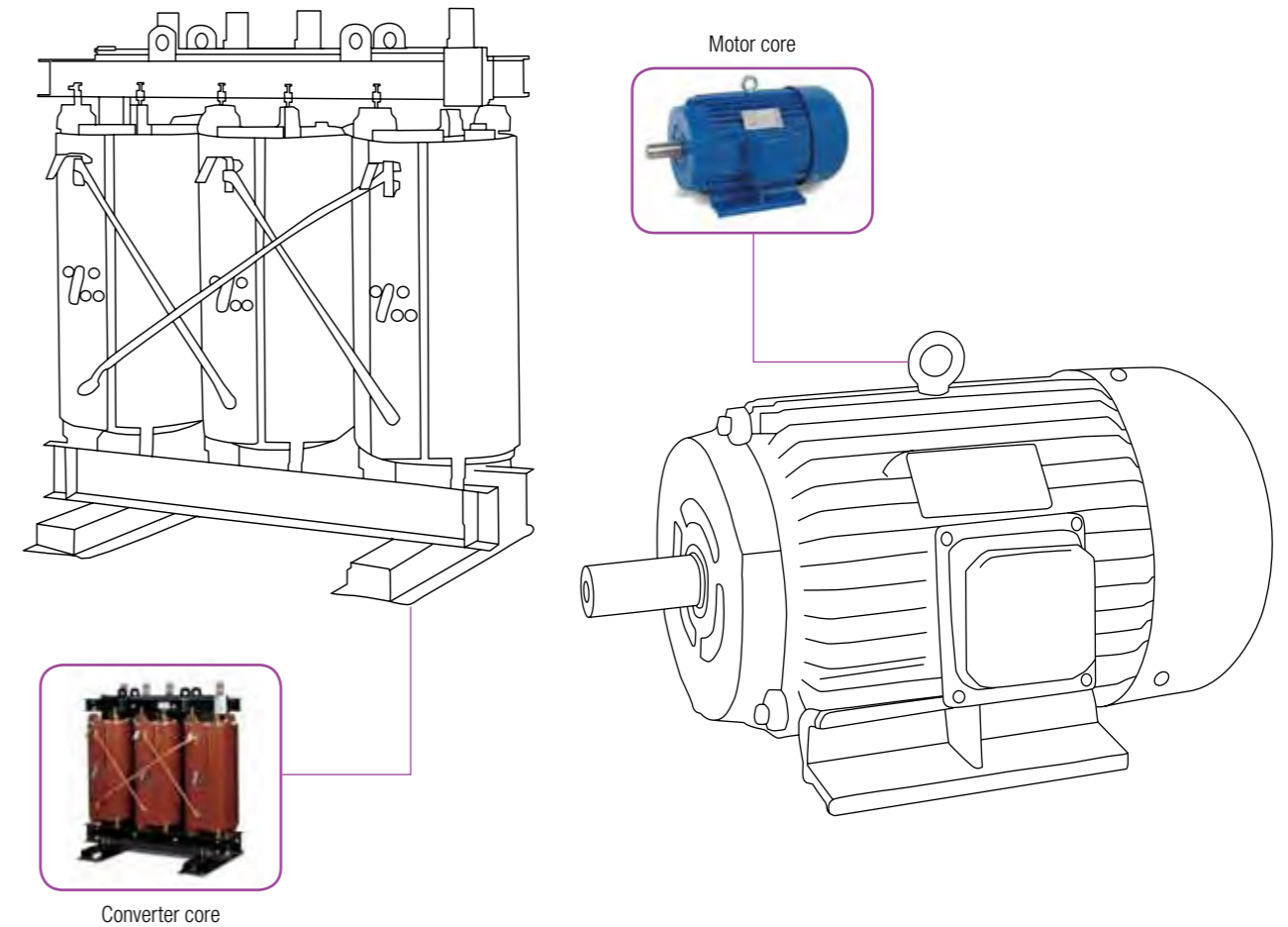

Grain-Oriented Electrical Steel

PG-Core

The grain structure of PG-core is oriented to the rolling direction. Therefore, this product has excellent magnetic properties in the rolling direction. It is widely used for large or mid/small-size transformers.

Standard Size

Product	Grade	Thickness mm (in.)	Width mm (in.)		Internal diameter mm (in.)
			Available	Standard	
PG-Core	27PG110	0.27 (0.0106)	850~1200 (33.46~47.24)	1000 (39.37)	508 (20)
	27PG120				
	27PG130				
	30PG110	0.30 (0.0118)			
	30PG120				
	30PG130				
	30PG140				
	35PG145				
	35PG155				

Note) For non-standard sizes, please contact us

Specification

Magnetic properties and lamination factors

Grade	Thickness mm (in.)	Density (kg/dm ³)	Core Loss, Max (W17/50)		Magnetic Flux Density, Min T(B8)	Lamination Factor, Min(%)	
			Watt per kilogram	Watt per pound			
27PG110	0.27 (0.0106)	7.65	1.10	0.50	1.80	95.0	
27PG120			1.20	0.54			
27PG130			1.30	0.59			
30PG110	0.30 (0.0118)		1.10	0.50		1.80	95.5
30PG120			1.20	0.54			
30PG130			1.30	0.59			
30PG140			1.40	0.64			
35PG145			0.35 (0.0138)	1.45			
35PG155	1.55			0.70			

Note) Above test is conducted in accordance with IEC60404-2 (or JIS C 2550-2000).

W17/50 indicates the core loss at the frequency of 50 Hz and the magnetic flux density of 1.7T. B8 indicates the magnetic flux density at 800A/m. Core loss and magnetic flux density are measured after stress relief annealing in a rolling direction. (annealing condition : 840°C, 1Hr, Under non-oxidation atmosphere)

Dimension & Shape Tolerance

Width mm (in.)	Thickness mm (in.)	Thickness Tolerance mm (in.)	Thickness deviation in transverse direction mm (in.)	Width Tolerance mm (in.)	Camber(Length : 2m) mm (in.)
850 and over (33.46)	0.27(0.0106)	±0.03 (0.0012)	0.03(0.0012) and under	+0.6(0.0236) 0	1.0(0.0394) and under
	0.30(0.0118)				
	0.35(0.0138)				

Note) Thickness deviation in width direction means the gap between the thickness of center and the one section 15mm away from the edge part.

Typical Electrical and Magnetic Properties

Grade	Thickness mm (in.)	Density (kg/dm ³)	Resistivity Ω·m (×10 ⁻⁸)	Core Loss								Magnetic Flux Density, T(B8)
				Watt per kilogram				Watt per pound				
				W15/50	W17/50	W15/60	W17/60	W15/50	W17/50	W15/60	W17/60	
27PG110	0.27 (0.0106)	7.65	48	0.76	1.05	1.01	1.37	0.35	0.48	0.46	0.62	1.85
27PG120				0.78	1.15	1.02	1.48	0.35	0.52	0.46	0.67	1.85
27PG130				0.82	1.22	1.07	1.55	0.37	0.55	0.49	0.70	1.84
30PG110	0.30 (0.0118)			0.80	1.08	1.05	1.48	0.36	0.49	0.48	0.67	1.85
30PG120				0.83	1.17	1.09	1.53	0.38	0.53	0.49	0.69	1.85
30PG130				0.87	1.25	1.12	1.61	0.40	0.57	0.51	0.73	1.84
30PG140				0.90	1.32	1.17	1.70	0.41	0.60	0.53	0.77	1.84
35PG145				0.35 (0.0138)	0.98	1.37	1.29	1.80	0.44	0.62	0.59	0.82
35PG155	1.01				1.45	1.33	1.89	0.46	0.66	0.61	0.86	1.83

Note) Above values are not guaranteed. Tests are conducted in accordance with IEC 60404-2 (or JIS C 2550-1) method, using specimens taken longitudinal to the rolling direction and annealed to develop full magnetic properties.

Typical Mechanical Property and Lamination Factor

Thickness mm (in.)	Tensile Strength(N/mm ²)		Yield Point(N/mm ²)		Elongation(%)		Hardness Hv1	Lamination Factor(%)
	L	C	L	C	L	C		
0.27(0.0106)	344	385	322	340	11	44	182	97.5
0.30(0.0118)	345	412	330	350	12	49	180	98.0
0.35(0.0138)	364	423	345	357	10	40	181	98.3

Note) 1. Tests are conducted in accordance with JIS Z 2241 and 2244.

2. L : Specimens taken longitudinal to the rolling direction / C : Specimens taken transverse to the rolling direction

3. Specimens with OA coating are used for lamination factor test.

Grain-Oriented Electrical Steel

PH-Core

The degree of grain-oriented is reinforced in the rolling direction more than PG-Core and therefore features lower core loss and higher magnetic flux density. It is used for iron core of both large and other size power transformers and desirable for high efficiency and miniaturization of machinery.

Standard Size

Product	Grade	Thickness mm (in.)	Width mm (in.)		Inside diameter mm (in.)
			Available	Standard	
PH-Core	23PH085	0.23 (0.0091)	850~1200 (33.46~47.24)	1000 (39.37)	508 (20)
	23PH090				
	23PH095				
	23PH100				
	27PH095	0.27 (0.0106)			
	27PH100				
	27PH110				
	30PH100	0.30 (0.0118)			
30PH105					

Note) For non-standard sizes, please contact us

Specification

Magnetic properties and lamination factors

Grade	Thickness mm (in.)	Density (kg/dm ³)	Core Loss, Max (W17/50)		Magnetic Flux Density, Min T(B8)	Lamination Factor, Min(%)
			Watt per kilogram	Watt per pound		
23PH085	0.23 (0.0091)	7.65	0.85	0.39	1.88	94.5
23PH090			0.90	0.41		
23PH095			0.95	0.43		
23PH100			1.00	0.45		
27PH095	0.27 (0.0106)	7.65	0.95	0.43	1.88	95.0
27PH100			1.00	0.45		
27PH110			1.10	0.50		
30PH100	0.30 (0.0118)	7.65	1.00	0.45	1.88	95.5
30PH105			1.05	0.48		

Note) Above test is conducted in accordance with IEC60404-2 (or JIS C 2550-2000).

W17/50 indicates the core loss at the frequency of 50 Hz and the magnetic flux density of 1.7T. B8 indicates the magnetic flux density at 800A/m. Core loss and magnetic flux density are measured after stress relief annealing in a rolling direction. (annealing condition : 840°C, 1Hr, Under non-oxidation atmosphere)

Dimension & Shape Tolerance

Width mm (in.)	Thickness mm (in.)	Thickness Tolerance mm (in.)	Thickness deviation in transverse direction mm (in.)	Width Tolerance mm (in.)	Camber(Length : 2m) mm (in.)
850 and over (33.46)	0.23(0.0091)	±0.03 (0.0012)	0.03(0.0012) and under	+0.6(0.0236) 0	1.0(0.0394) and under
	0.27(0.0106)				
	0.30(0.0118)				

Note) Thickness deviation in width direction means the gap between the thickness of center and the one section 15mm away from the edge part.

Typical Electrical and Magnetic Properties

Grade	Thickness mm (in.)	Density (kg/dm ³)	Resistivity Ω·m (×10 ⁻⁸)	Core Loss								Magnetic Flux Density, T(B8)
				Watt per kilogram				Watt per pound				
				W15/50	W17/50	W15/60	W17/60	W15/50	W17/50	W15/60	W17/60	
23PH085	0.23 (0.0091)	7.65	48	0.62	0.83	0.81	1.10	0.28	0.38	0.37	0.50	1.91
23PH090				0.64	0.88	0.85	1.15	0.29	0.40	0.39	0.52	1.91
23PH095				0.65	0.90	0.86	1.17	0.30	0.41	0.39	0.53	1.91
23PH100				0.70	0.95	0.92	1.26	0.32	0.43	0.42	0.57	1.90
27PH095	0.27 (0.0106)	7.65	48	0.70	0.93	0.92	1.23	0.32	0.42	0.42	0.55	1.91
27PH100				0.72	0.97	0.95	1.27	0.33	0.44	0.43	0.58	1.90
27PH110				0.78	1.03	1.01	1.37	0.35	0.47	0.46	0.62	1.90
30PH100	0.30 (0.0118)	7.65	48	0.74	0.99	0.98	1.29	0.34	0.45	0.44	0.59	1.91
30PH105				0.76	1.01	1.00	1.33	0.35	0.46	0.45	0.60	1.90

Note) Above values are not guaranteed. Tests are conducted in accordance with IEC 60404-2 (or JIS C 2550-1) method, using specimens taken longitudinal to the rolling direction and annealed to develop full magnetic properties.

Typical Mechanical Property and Lamination Factor

Thickness mm (in.)	Tensile Strength(N/mm ²)		Yield Point(N/mm ²)		Elongation(%)		Hardness Hv1	Lamination Factor(%)
	L	C	L	C	L	C		
0.23(0.0091)	381	424	356	383	14	42	183	97.0
0.27(0.0106)	361	415	337	367	14	42	182	97.5
0.30(0.0118)	345	412	330	358	16	45	184	98.0

Note) 1. Tests are conducted in accordance with JIS Z 2241 and 2244.

2. L : Specimens taken longitudinal to the rolling direction / C : Specimens taken transverse to the rolling direction

3. Specimens with OA coating are used for lamination factor test.

Grain-Oriented Electrical Steel

PHD-Core

Magnetic domain refined steel is the product that has been specially treated with laser scribing to lower the core loss by ~30% from that of CGO steel. Energy efficiency is higher and magnetostriction is lowered, resulting in low noise of this domain refined steel. It is used for Not needed. Power transformers that have not been heat treated.

Standard Size

Product	Grade	Thickness mm (in.)	Width mm (in.)		Inside diameter mm (in.)
			Available	Standard	
PHD-Core	23PHD080	0.23(0.0091)	850~1200 (33.46~47.24)	1000	508 (20)
	23PHD085			(39.37)	
	27PHD090	1200 (47.24)			
	27PHD095				
	30PHD095	0.030(0.0118)			

Note) For non-standard sizes, please contact us

Specification

Magnetic properties and lamination factors

Grade	Thickness mm (in.)	Density (kg/dm ³)	Core Loss, Max (W17/50)		Magnetic Flux Density.Min T(B8)	Lamination Factor, Min(%)
			Watt per kilogram	Watt per pound		
23PHD080	0.23(0.0091)	7.65	0.80	0.36	1.88	94.5
23PHD085			0.85	0.39		
27PHD090	0.27(0.0106)		0.90	0.41	1.88	95.0
27PHD095			0.95	0.43		
30PHD095	0.030(0.0118)		0.95	0.43		

Note) 1. Above test is conducted in accordance with IEC60404-3 (or JIS C 2556-1996), using single sheet tester, without stress relief annealing.
2. Laser treatment is offset by the effect of the product heat treatment as a temporary magnetic domain refining treatment POSCO products.
3. W17/50 indicates the core loss at the frequency of 50 Hz and the magnetic flux density of 1.7T. B8 indicates the magnetic flux density at 800A/m

Dimension & Shape Tolerance

Width mm (in.)	Thickness mm (in.)	Thickness Tolerance mm (in.)	Thickness deviation in transverse direction mm (in.)	Width Tolerance mm (in.)	Camber (Length : 2m) mm (in.)
850 and over (33.46)	0.23(0.0091)	±0.03 (0.0012)	0.03(0.0012)	+0.6(0.0236)	1.0(0.0394)
	0.27(0.0106)		and under	0	and under
	0.30(0.0118)				

Note) Thickness deviation in width direction means the gap between the thickness of center and the one section 15mm away from the edge part.

Typical Electrical and Magnetic Properties

Grade	Thickness mm (in.)	Density (kg/dm ³)	Resistivity Ω·m (×10 ⁻⁸)	Core Loss								Magnetic Flux Density. T(B8)
				Watt per kilogram				Watt per pound				
				W15/50	W17/50	W15/60	W17/60	W15/50	W17/50	W15/60	W17/60	
23PHD080	0.23	7.65	48	0.57	0.77	0.75	1.01	0.26	0.35	0.34	0.46	1.91
23PHD085	(0.0091)			0.59	0.80	0.78	1.05	0.27	0.36	0.35	0.48	1.91
27PHD090	0.27			0.64	0.87	0.85	1.14	0.29	0.40	0.39	0.52	1.91
27PHD095	(0.0106)			0.66	0.91	0.86	1.18	0.30	0.41	0.39	0.54	1.91
30PHD095	0.30(0.0118)			0.68	0.93	0.91	1.23	0.31	0.42	0.41	0.56	1.91

Note) Above values are not guaranteed. Tests are conducted in accordance with IEC60404-2 (or JIS C 2556-1996) method, using as-sheared specimens in longitudinal to rolling direction, without stress relief annealing.

Typical Mechanical Property and Lamination Factor

Thickness mm (in.)	Tensile Strength(N/mm ²)		Yield Point(N/mm ²)		Elongation(%)		Hardness Hv1	Lamination Factor(%)
	L	C	L	C	L	C		
0.23(0.0091)	381	424	356	383	14	42	183	97.0
0.27(0.0106)	361	415	337	367	14	42	185	97.5
0.30(0.0118)	345	412	330	358	16	45	183	98.0

Note) 1. Tests are conducted in accordance with JIS Z 2241 and 2244.
2. L : Specimens taken longitudinal to the rolling direction / C : Specimens taken transverse to the rolling direction
3. Specimens with OA coating are used for lamination factor test.

Non-Oriented Electrical Steel

PN-Core

Non-oriented electrical steel features homogeneous magnetic properties in all directions. They are widely used as iron core materials in rotating machines ranging from large power generators to tiny precision electric motors. They are also used in the iron core of small power transformers.

Standard Size

Product	Grade	Thickness mm (in.)	Width mm (in.)		Inside diameter mm (in.)
			Available	Standard	
PN-Core(Coil)	35PN210, 35PN230, 35PN250, 35PN270, 35PN300	0.35(0.0138)	950~1200	1000 (39.37)	508 (20)
	50PN250, 50PN270, 50PN290, 50PN310, 50PN350	0.50(0.0197)	(37.40~47.24)		
	35PN360, 35PN440	0.35(0.0138)	950~1250 (37.40~49.21)		
	50PN400, 50PN470, 50PN600, 50PN700, 50PN800	0.50(0.0197)			
	50PN1000, 50PN1300	0.65(0.0256)	1200 (47.24)		
	65PN400, 65PN470, 65PN600, 65PN700, 65PN800				
	65PN1000, 65PN1300				

Note) For non-standard sizes, please contact us

Specification

Magnetic properties and lamination factors

Grade	Thickness mm (in.)	Density (kg/dm ³)	Core Loss, Max (W15/50)		Magnetic Flux Density.Min T(B50)	Lamination Factor, Min(%)
			Watt per kilogram	Watt per pound		
35PN210	0.35(0.0138)	7.60	2.10	0.95	1.62	95.0
35PN230		7.60	2.30	1.04	1.62	
35PN250		7.60	2.50	1.14	1.62	
35PN270		7.65	2.70	1.23	1.62	
35PN300		7.65	3.00	1.36	1.62	
35PN360		7.65	3.60	1.63	1.63	
35PN440		7.70	4.40	2.00	1.65	

Grade	Thickness mm (in.)	Density (kg/dm ³)	Core Loss, Max (W15/50)		Magnetic Flux Density.Min T(B50)	Lamination Factor, Min(%)
			Watt per kilogram	Watt per pound		
50PN250	0.50(0.0197)	7.60	2.50	1.14	1.62	96.0
50PN270		7.60	2.70	1.23	1.62	
50PN290		7.60	2.90	1.32	1.62	
50PN310		7.65	3.10	1.41	1.62	
50PN350		7.65	3.50	1.59	1.62	
50PN400		7.65	4.00	1.82	1.63	
50PN470		7.70	4.70	2.13	1.64	
50PN600		7.75	6.00	2.72	1.66	
50PN700		7.80	7.00	3.18	1.70	
50PN800		7.85	8.00	3.63	1.70	
50PN1000		7.85	10.00	4.54	1.70	
50PN1300		7.85	13.00	5.90	1.70	
65PN400		0.65(0.0256)	7.65	4.00	1.82	
65PN470	7.70		4.70	2.13	1.65	
65PN600	7.75		6.00	2.72	1.65	
65PN700	7.80		7.00	3.18	1.65	
65PN800	7.85		8.00	3.63	1.65	
65PN1000	7.85		10.00	4.54	1.65	
65PN1300	7.85		13.00	5.90	1.65	

Note) 1. Above test is conducted in accordance with IEC60404-2 (or JIS C 2550-1), using as-sheared specimens taken one half longitudinal and one half transverse to the rolling direction.
2. W15/50 indicates the core loss at the frequency of 50 Hz and the magnetic flux density of 1.5T.
3. B50 indicates the magnetic flux density at 5000A/m

Dimension & Shape Tolerance

Width mm (in.)	Thickness mm (in.)	Thickness Tolerance mm (in.)	Thickness deviation in transverse direction mm (in.)	Width Tolerance mm (in.)	Camber(Length : 2m) mm (in.)
1000(39.37) and under	0.35(0.0138)	±0.035(0.00138)	0.02(0.0008)and under	+1.5(0.0591)	1.0(0.0394) and under
	0.50(0.0197)	±0.040(0.00158)	0.03(0.0012)and under	0	
	0.65(0.0256)	±0.052(0.00205)	0.04(0.0016)and under	0	
1000(39.37) and over	0.35(0.0138)	±0.035(0.00138)	0.03(0.0012)and under	+1.5(0.0591)	1.0(0.0394) and under
	0.50(0.0197)	±0.040(0.00158)	0.04(0.0016)and under	0	
	0.65(0.0256)	±0.052(0.00205)	0.04(0.0016)and under	0	

Note) Thickness deviation in width direction means the gap between the thickness of center and the one section 15mm away from the edge part.

Non-Oriented Electrical Steel

Typical Electrical and Magnetic Property

Grade	Thickness mm (in.)	Density (kg/dm ³)	Resistivity Ω·m (×10 ⁻⁸)	Core Loss								Magnetic Flux Density (T)	
				Watt per kilogram				Watt per pound				B25	B50
				W10/50	W15/50	W10/60	W15/60	W10/50	W15/50	W10/60	W15/60		
35PN210	0.35(0.0138)	7.60	59	0.84	2.04	1.03	2.53	0.38	0.93	0.47	0.17	1.56	1.65
35PN230		7.60	59	0.89	2.10	1.07	2.60	0.40	0.95	0.49	0.18	1.57	1.66
35PN250		7.60	55	0.96	2.25	1.17	2.85	0.43	1.02	0.53	0.20	1.57	1.66
35PN270		7.65	52	1.02	2.40	1.28	3.00	0.46	1.09	0.58	0.21	1.58	1.67
35PN300		7.65	45	1.08	2.53	1.38	3.18	0.49	1.15	0.63	0.22	1.59	1.69
35PN360		7.65	45	1.25	2.80	1.55	3.45	0.57	1.27	0.70	0.26	1.59	1.69
35PN440		7.70	42	1.39	3.08	1.73	3.82	0.63	1.40	0.79	0.29	1.62	1.71
50PN250		0.50(0.0197)	7.60	59	1.00	2.37	1.31	3.08	0.45	1.08	0.59	1.40	1.57
50PN270	7.60		59	1.05	2.50	1.35	3.22	0.48	1.14	0.61	1.46	1.57	1.67
50PN290	7.60		56	1.09	2.60	1.45	3.35	0.50	1.18	0.65	1.52	1.58	1.67
50PN310	7.65		53	1.21	2.70	1.55	3.46	0.55	1.23	0.70	1.57	1.59	1.68
50PN350	7.65		50	1.30	2.93	1.63	3.74	0.59	1.33	0.74	1.70	1.60	1.69
50PN400	7.65		45	1.41	3.18	1.82	4.01	0.64	1.44	0.83	1.82	1.61	1.70
50PN470	7.70		42	1.64	3.55	2.06	4.56	0.74	1.61	0.94	2.07	1.61	1.70
50PN600	7.75		34	1.98	4.40	2.49	5.63	0.90	2.00	1.13	2.56	1.62	1.71
50PN700	7.80		30	2.62	5.55	3.30	7.03	1.19	2.52	1.50	3.19	1.64	1.72
50PN800	7.85		17	2.93	6.26	3.63	7.94	1.33	2.84	1.65	3.60	1.66	1.74
50PN1000	7.85		17	3.20	6.80	4.10	8.62	1.45	3.09	1.86	3.91	1.67	1.75
50PN1300	7.85		17	3.75	7.56	4.75	9.54	1.70	3.43	2.16	4.33	1.67	1.75
65PN400	0.65(0.0256)	7.65	45	1.63	3.70	2.23	4.85	0.74	1.68	1.01	2.20	1.62	1.70
65PN470		7.70	42	1.91	4.16	2.59	5.45	0.87	1.89	1.18	2.47	1.62	1.70
65PN600		7.75	34	2.27	5.14	3.09	6.68	1.03	2.33	1.40	3.03	1.63	1.72
65PN700		7.80	30	3.02	6.47	4.06	8.33	1.37	2.94	1.84	3.78	1.65	1.73
65PN800		7.85	17	3.38	7.28	4.56	9.39	1.53	3.30	2.07	4.26	1.67	1.75
65PN1000		7.85	17	3.64	7.86	5.00	10.14	1.65	3.57	2.27	4.60	1.68	1.75
65PN1300		7.85	17	4.32	8.79	5.83	11.29	1.96	4.00	2.65	5.13	1.68	1.75

Note) Above values are not guaranteed. Tests are conducted in accordance with IEC 60404-2 (or JIS C 2550-1) method, using as-sheared specimens taken one half longitudinal and one half transverse to the rolling direction.

Typical Mechanical Property and Lamination Factor

Grade	Thickness mm (in.)	Tensile Strength(N/mm ²)		Yield Point(N/mm ²)		Elongation(%)		Hardness Hv1	Lamination Factor(%)
		L	C	L	C	L	C		
		35PN210	0.35(0.0138)	538	547	415	427	18	19
35PN230	535	545		393	403	19	20	216	
35PN250	522	539		370	385	19	21	214	
35PN270	467	485		347	361	21	23	190	
35PN300	456	469		336	351	21	23	188	
35PN360	450	470		350	366	23	25	170	
35PN440	405	415		273	285	27	29	150	
50PN250	0.50(0.0197)	550		570	413	426	20	22	223
50PN270		535	550	406	460	22	23	205	
50PN290		510	530	370	386	23	25	195	
50PN310		483	505	355	361	25	28	189	
50PN350		470	489	344	354	25	28	189	
50PN400		465	482	352	365	27	30	183	
50PN470		415	420	275	285	34	36	143	
50PN600		395	405	268	278	37	39	130	
50PN700		385	395	270	280	38	39	120	
50PN800		375	385	270	280	39	40	115	
50PN1000		370	380	265	275	40	41	113	
50PN1300		350	360	250	260	40	41	105	
65PN400	0.65(0.0256)	479	510	370	380	31	30	180	98.0
65PN470		425	440	300	315	35	36	146	
65PN600		395	430	278	288	37	38	130	
65PN700		386	405	273	285	39	41	121	
65PN800		375	385	270	280	40	41	113	
65PN1000		370	380	265	275	41	42	110	
65PN1300		350	360	250	260	41	42	110	

Note) 1. Tests are conducted in accordance with JIS Z 2241 and 2244.
 2. L : Specimens taken longitudinal to the rolling direction / C : Specimens taken transverse to the rolling direction
 3. Specimens with C-6A coating are used for lamination factor test.

Non-Oriented Electrical Steel

PNM-Core

Non-oriented electrical steel features homogeneous magnetic properties in all directions. It is a popular material for magnetic switches as it offers improved wear resistance and low residual magnetism.

Standard Size

Product	Grade	Thickness mm (in.)	Width mm (in.)		Inside diameter mm (in.)
			Available	Standard	
PNM-Core(Coil)	65PNM540	0.65(0.0256)	950~1200 (37.40~47.24)	1000(39.37)	508 (20)
	70PNM500	0.70(0.0276)		1200(47.24)	

Note) For non-standard sizes, please contact us

Specification

Magnetic properties and lamination factors

Grade	Thickness mm (in.)	Density (kg/dm ³)	Core Loss, Max (W15/50)		Magnetic Flux Density, Min T(B50)	Lamination Factor, Min(%)
			Watt per kilogram	Watt per pound		
65PNM540	0.65(0.0256)	7.70	5.40	2.45	1.66	97.0
70PNM500	0.70(0.0276)	7.65	5.00	2.63	1.65	97.0

Note) 1. Above test is conducted in accordance with IEC60404-2 (or JIS C 2550-1), using as-sheared specimens taken one half longitudinal and one half transverse to the rolling direction.
2. W15/50 indicates the core loss at the frequency of 50 Hz and the magnetic flux density of 1.5T.
3. B50 indicates the magnetic flux density at 5000A/m

Dimension & Shape Tolerance

Width mm (in.)	Thickness mm (in.)	Thickness Tolerance mm (in.)	Thickness deviation in transverse direction mm (in.)	Width Tolerance mm (in.)	Camber(Length : 2m) mm (in.)
1000(39.37) and under	0.65(0.0256)	±0.052(0.00205)	0.04(0.0016)	+1.5(0.0591)	1.0(0.0394)
	0.70(0.0276)	±0.056(0.00221)	and under	0	
1000(39.37) and over	0.65(0.0256)	±0.052(0.00205)	0.04(0.0016)	+0.6(0.0591)	and under
	0.70(0.0276)	±0.056(0.00220)	and under	0	

Note) Thickness deviation in width direction means the gap between the thickness of center and the one section 15mm away from the edge part.

Typical Electrical and Magnetic Properties

Grade	Thickness mm (in.)	Density (kg/dm ³)	Resistivity Ω·m (×10 ⁻⁸)	Core Loss								Magnetic Flux Density, (T)	
				Watt per kilogram				Watt per pound				B25	B50
				W10/50	W15/50	W10/60	W15/60	W10/50	W15/50	W10/60	W15/60		
65PNM540	0.65 (0.0256)	7.70	42	1.80	3.72	2.27	4.81	0.82	1.69	1.03	2.18	1.65	1.72
70PNM500	0.70 (0.0276)	7.65	44	1.72	3.63	2.18	4.78	0.78	1.65	0.99	2.17	1.61	1.70

Note) Above values are not guaranteed. Tests are conducted in accordance with IEC 60404-2 (or JIS C 2550-1) method, using as-sheared specimens taken one half longitudinal and one half transverse to the rolling direction.

Typical Mechanical Property and Lamination Factor

Grade	Thickness mm (in.)	Tensile Strength(N/mm ²)		Yield Point(N/mm ²)		Elongation(%)		Hardness Hv1	Lamination Factor(%)
		L	C	L	C	L	C		
65PNM540	0.65 (0.0256)	437	452	300	315	32	33	155	98.0
70PNM500	0.70 (0.0276)	485	496	356	371	31	32	177	

Note) 1. Tests are conducted in accordance with JIS Z 2241 and 2244.
2. L : Specimens taken longitudinal to the rolling direction / C : Specimens taken transverse to the rolling direction
3. Specimens with C-6A coating are used for lamination factor test.

Non-Oriented Electrical Steel

PNF-Core

The Eddy current losses increase sharply compared to conventional 0.35mm compared to about 40% of Poles have 0.2mm products and thinning, The solid core loss characteristics at high frequencies.

Standard Size

Product	Grade	Thickness mm (in.)	Width mm (in.)		Inside diameter mm (in.)
			Available	Standard	
PNF-Core(Coil)	20PNF1500	0.20(0.0080)	950~1200 (37.40~47.24)	1000(39.37) 1100(43.31)	508 (20)
	30PNF1600	0.30(0.0118)			
	35PNF1800	0.35(0.0138)			

Note) For non-standard sizes, please contact us

Specification

Magnetic properties and lamination factors

Grade	Thickness mm (in.)	Density (kg/dm ³)	Core Loss, Max (W10/400)		Magnetic Flux Density, Min T(B50)	Lamination Factor, Min(%)
			Watt per kilogram	Watt per pound		
20PNF1500	0.20(0.0080)	7.65	15.0	6.80	1.62	93.0
30PNF1600	0.30(0.0118)	7.60	16.0	7.26	1.62	94.5
35PNF1800	0.35(0.0138)	7.60	18.0	8.17	1.62	95.0

Note) 1. Above test is conducted in accordance with IEC60404-2 (or JIS C 2550-1), using as-sheared specimens one half longitudinal and one half transverse to the rolling direction.
2. W10/400 indicates the core loss at the frequency of 400 Hz and magnetic flux density of 1.0T.
3. B50 indicates magnetic flux density at 5000A/m

Dimension & Shape Tolerance

Width mm (in.)	Thickness mm (in.)	Thickness Tolerance mm (in.)	Thickness deviation in transverse direction mm (in.)	Width Tolerance mm (in.)	Camber(Length : 2m) mm (in.)
1000(39.37) and under	0.20(0.0080)	±0.020(0.0008)	0.02(0.0008) and under	+1.5(0.0591) 0	1.0(0.0394) and under
	0.30(0.0118)	±0.030(0.0012)			
	0.35(0.0138)	±0.035(0.0014)			
1000(39.37) and over	0.20(0.0080)	±0.020(0.0008)	0.03(0.0012) and under	+1.5(0.0591) 0	1.0(0.0394) and under
	0.30(0.0118)	±0.030(0.0012)			
	0.35(0.0138)	±0.035(0.0014)			

Note) Thickness deviation in width direction means the gap between the thickness of center and the one section 15mm away from the edge part.

Typical Electrical and Magnetic Properties

Grade	Thickness mm (in.)	Density (kg/dm ³)	Resistivity Ω·m (×10 ⁻⁸)	Core Loss										Magnetic Flux Density (T)	
				Watt per kilogram					Watt per pound					B25	B50
				W10/50	W15/50	W10/60	W15/60	W10/400	W10/50	W15/50	W10/60	W15/60	W10/400		
20PNF1500	0.20 (0.0080)	7.65	50	1.24	2.71	1.53	3.28	12.8	0.56	1.23	0.69	1.49	5.76	1.57	1.66
30PNF1600	0.30 (0.0118)	7.60	59	0.93	2.16	1.17	2.72	14.8	0.422	0.98	0.53	1.23	6.71	1.56	1.66
35PNF1800	0.35 (0.0138)	7.60	59	0.97	2.19	1.20	2.73	16.9	0.44	0.99	0.54	1.24	7.67	1.56	1.66

Note) Above values are not guaranteed. W10/400 indicates the core loss at the frequency of 400 Hz and magnetic flux density of 1.0T. Tests are conducted in accordance with IEC 60404-2 (or JIS C 2550-1) method,

Typical Mechanical Property and Lamination Factor

Grade	Thickness mm (in.)	Tensile Strength(N/mm ²)		Yield Point(N/mm ²)		Elongation(%)		Hardness Hv1	Lamination Factor(%)
		L	C	L	C	L	C		
20PNF1500	0.20 (0.0080)	471	490	363	381	16	19	195	97.0
30PNF1600	0.30 (0.0118)	535	545	416	426	18	19	223	97.5
35PNF1800	0.35 (0.0138)	536	546	418	428	19	20	224	97.5

Note) 1. Tests are conducted in accordance with JIS Z 2241 and 2244.
2. L : Specimens taken longitudinal to the rolling direction / C : Specimens taken transverse to the rolling direction
3. Specimens with C-6A coating are used for lamination factor test.

Comparison of Core Loss with Frequency

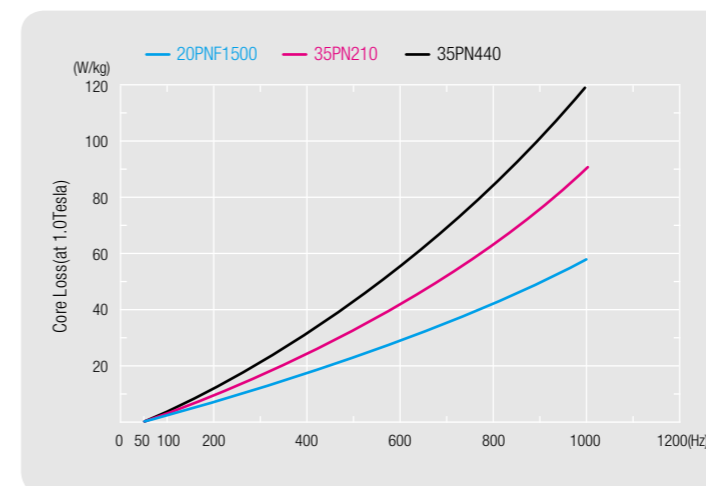

Having low iron loss characteristics in the high frequency region of the eddy current losses increase rapidly for high-frequency ultra-thin non-oriented electrical steel products, and are expected to 0.35mm Compared to W10 / 400 characteristics 35PN 210 and 30% excellent.

Non-Oriented Electrical Steel

PNA-Core

After annealing (SRA, Stress Relief Annealing) material for cost savings for our clients improve competitiveness. The product has a low iron loss, flux density, and processing characteristics.

Standard Size

Product	Grade	Thickness mm (in.)	Width mm (in.)		Inside diameter mm (in.)
			Available	Standard	
PNA-Core(Coil)	50PNA300	0.50 (0.0197)	950~1200 (37.40~47.24)	1000(39.37)	508 (20)
	50PNA350			1100(43.31)	
	50PNA450			1200(47.24)	

Note) For non-standard sizes, please contact us

Specification

Magnetic properties and lamination factors

Grade	Thickness mm (in.)	Density (kg/dm ³)	Core Loss, Max (W15/50)		Magnetic Flux Density, Min T(B50)	Lamination Factor, Min(%)
			Watt per kilogram	Watt per pound		
50PNA300	0.50(0.0197)	7.75	3.0	1.36	1.70	96.0
50PNA350	0.50(0.0197)	7.75	3.5	1.59	1.70	96.0
50PNA450	0.50(0.0197)	7.80	4.5	2.13	1.70	96.0

Note) 1. Above test is conducted in accordance with IEC60404-2 (or JIS C 2550-1), using specimens one half longitudinal and one half transverse to the rolling direction. Core loss and magnetic flux density are measured after stress relief annealing. (Annealing condition : 750°C×2hrs, under non-oxidation atmosphere)
2. W15/50 indicates the core loss at the frequency of 50 Hz and magnetic flux density of 1.5T. B50 indicates the magnetic flux density at 5000A/m

Dimension & Shape Tolerance

Width mm (in.)	Thickness mm (in.)	Thickness Tolerance mm (in.)	Thickness deviation in transverse direction mm (in.)	Width Tolerance mm (in.)	Camber(Length : 2m) mm (in.)
1000(39.37) and under	0.5 (0.0197)	±0.040 (0.00158)	0.03(0.0012) and under	+1.5(0.0591) 0	1.0(0.0394)
1000(39.37) and over	0.5 (0.0197)	±0.040 (0.00158)	0.04(0.0016) and under	+1.5(0.0591) 0	and under

Note) Thickness deviation in width direction means the gap between the thickness of center and the one section 15mm away from the edge part.

Typical Electrical and Magnetic Properties

Grade	Thickness mm (in.)	Resistivity Ω·m (×10 ⁻⁸)	Core Loss								Magnetic Flux Density. (T)	
			Watt per kilogram				Watt per pound				B25	B50
			W10/50	W15/50	W10/60	W15/60	W10/50	W15/50	W10/60	W15/60		
50PNA300	0.50 (0.0197)	37	1.29	2.70	1.72	3.71	0.59	1.35	0.78	1.68	1.65	1.73
50PNA350	0.50 (0.0197)	33	1.36	3.05	1.83	3.91	0.62	1.38	0.83	1.77	1.67	1.74
50PNA450	0.50 (0.0197)	20	1.73	3.89	2.22	5.11	0.79	1.77	1.01	2.32	1.63	1.72

Note) Above values are not guaranteed. Tests are conducted in accordance with IEC 60404-2 (or JIS C 2550-1) method, after stress relief annealing. (Annealing conditions: 750°C (1380°F) × 2hrs, under neutral atmosphere)

Typical Mechanical Property and Lamination Factor

Grade	Thickness mm (in.)	Tensile Strength(N/mm ²)		Yield Point(N/mm ²)		Elongation(%)		Hardness Hv1	Lamination Factor(%)
		L	C	L	C	L	C		
50PNA300	0.50 (0.0197)	402	415	260	269	37	39	141	98.0
50PNA350	0.50 (0.0197)	382	401	268	278	36	38	124	
50PNA450	0.50 (0.0197)	372	381	269	270	37	38	117	

Note) 1. Tests are conducted in accordance with JIS Z 2241 and 2244.
2. L : Specimens taken longitudinal to the rolling direction / C : Specimens taken transverse to the rolling direction
3. Specimens with C-6A coating are used for lamination factor test.

Magnetic Property and Puncturability Comparison(PNA-Core VS PN-Core)

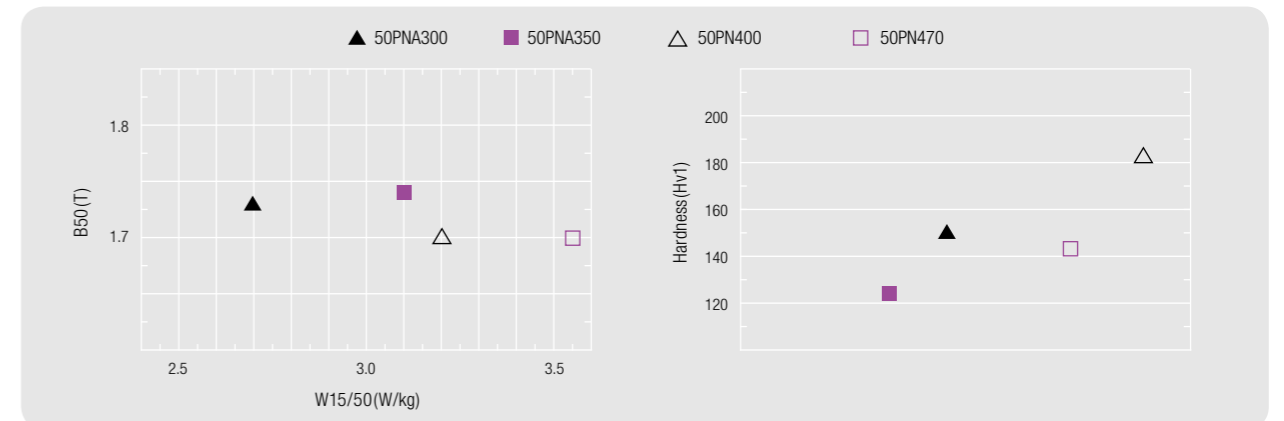

Through higher induction and punchability, PNA-core features higher efficiency of products and longer life of dies.

Non-Oriented Electrical Steel

PNS-Core

PNS-Core has less strength compared to Hyper grade non-oriented steel of 50PN250. to improve punchability of customer resatyi in increased life cycle of mold .

Standard Size

Product	Grade	Thickness mm (in.)	Width mm (in.)		Inside diameter mm (in.)
			Available	Standard	
PNS-Core(Coil)	35PNS250	0.35 (0.0138)	950~1200 (37.40~47.24)	1000(39.37) 1050(41.34) 1100(43.31)	508 (20)

Note) For non-standard sizes, please contact us

Specification

Magnetic properties and lamination factors

Grade	Thickness mm (in.)	Density (kg/dm ³)	Core Loss, Max (W15/50)		Magnetic Flux Density, Min T(B50)	Lamination Factor, Min(%)
			Watt per kilogram	Watt per pound		
35PNS250	0.35(0.0138)	7.60	2.5	1.14	1.63	95.0 이상

Note) 1. Above test is conducted in accordance with IEC60404-2 (or JIS C 2550-1), using as-sheared specimens taken one half longitudinal and one half transverse to the rolling direction.
2. W15/50 indicates the core loss at the frequency of 50 Hz and the magnetic flux density of 1.5T. 3. B50 indicates the magnetic flux density at 5000A/m

Dimension & Shape Tolerance

Width mm (in.)	Thickness mm (in.)	Thickness Tolerance mm (in.)	Thickness deviation in transverse direction mm (in.)	Width Tolerance mm (in.)	Camber(Length : 2m) mm (in.)
1000(39.37) and under	0.35 (0.0138)	±0.035 (0.00138)	0.02(0.0008) and under	+1.5(0.0591) 0	1.0(0.0394) and under
1000(39.37) and over	0.35 (0.0138)	±0.035 (0.00138)	0.03(0.0012) and under	+1.5(0.0591) 0	

Note) Thickness deviation in width direction is the difference between the thickness of center and 15mm from the edge.

Typical Electrical and Magnetic Properties

Grade	Thickness mm (in.)	Resistivity Ω·m (×10 ⁻⁹)	Core Loss								Magnetic Flux Density, (T)	
			Watt per kilogram				Watt per pound				B25	B50
			W10/50	W15/50	W10/60	W15/60	W10/50	W15/50	W10/60	W15/60		
35PNS250	0.35 (0.0138)	56	0.98	2.25	1.22	2.83	0.45	1.02	0.55	1.29	1.57	1.66

Note) Above values are not guaranteed. Tests are conducted in accordance with IEC 60404-2 (or JIS C 2550-1) method, using as-sheared specimens taken one half longitudinal and one half transverse to the rolling direction.

Typical Mechanical Property and Lamination Factor

Grade	Thickness mm (in.)	Tensile Strength(N/mm ²)		Yield Point(N/mm ²)		Elongation(%)		Hardness Hv1	Lamination Factor(%)
		L	C	L	C	L	C		
35PNS250	0.35 (0.0138)	442	445	330	332	23	25	186	98.0

Note) 1. Tests are conducted in accordance with JIS Z 2241 and 2244.
2. L : Specimens taken longitudinal to the rolling direction / C : Specimens taken transverse to the rolling direction
3. Specimens with C-6A coating are used for lamination factor test.

Surface Insulation

Types and Features of Surface Insulation

	GO		NO					Notice	
	General	Eco-friendly	General		Eco-friendly				
	OA	GS	C-6A (thin)	C-9A (middle)	NS (thin)	NM (middle)	NT (thick)		
Applied Spec	GO		NO						
Composition	Inorganic	Inorganic	organic/filler	organic/filler	organic/filler	organic/filler	organic/filler		
Thickness(μm)	2.0~5.0	2.0~5.0	0.5~1.0	1.2~1.8	0.5~1.0	1.2~1.8	5.0~7.0		
Resistivity (Ωcm ² /sheet)	Before SRA	15	15	0.5	5.0	3.0	5.0	50	ASTM A 717 SRA condition : 750°C×2hrs. in DX rich gas
	After SRA	15	15	0.1	0.5	1.5	2.5	SRA Not Accepted	
Lamination Factor(%)	95.0	95.0	98.0	98.0	98.0	98.0	97.0	1.0MPa±0.05 in Pressure(JIS C2550)	
Heat resistance (flaking after SRA)	Continuous	Not recognized	Not recognized	Not recognized	Not recognized	Not recognized	Not recognized	SRA Not Accepted	155°C×24hr in Air.
	Short	Not recognized	Not recognized	Not recognized	Not recognized	Not recognized	Not recognized	SRA Not Accepted	750°C×2hrs. in DX rich gas
Weathering (powdering)	Not recognized	Not recognized	Not recognized	Not recognized	Not recognized	Not recognized	Not recognized	Not recognized	65°C, 95% humidity, 72Hr
Adhesion (mmφ)	Before SRA (Mandrel bend tester)	30	30	10	10	10	10	20	ISO 1519
	After SRA (Cross cut tester)	-	-	5B	5B	5B	5B	5B	ASTM D3359B [0B (poor)~5B (excellent)]
Resistance to refrigerants	Change of surface	-	-	Not recognized	Not recognized	Not recognized	Not recognized	-	R-134a/Freol @15C= 65g/100g (130°C, 21day, 0.45μm filter paper)
	Change of weight	-	-	Not recognized	Not recognized	Not recognized	Not recognized	-	
Weldability	-	-	Excellent	Nomal	Good	Nomal	Not allowed		Current : 100~150A Ar 99% flow : 10~20L/min Speed : 0.25~0.50mpm

Note) Please designate surface insulation according to usage. Regarding coating properties, please contact us.
The coating thickness and the resistivity is typical value, not guaranteed.

Stress Relief Annealing

Stress relief annealing is a process that is carried out to acquire desired magnetic properties of electrical steel sheets by relieving stress generated in the process of shearing and punching at a proper temperature for a certain period of time.

Annealing Temperature

If the annealing temperature is too low, it is difficult to achieve adequate magnetic properties. If the temperature is too high, it may erode surface insulation, cause fusion between layers, and degrade core properties. The optimum annealing temperature to produce desirable magnetic properties is 780°C to 840°C for grain-oriented electrical steel and 750°C to 800°C for non-oriented electrical steel.

Annealing Time

Annealing time means the in-furnace time of materials at the highest temperature during the annealing process. During this time, the materials in the furnace should be evenly heated. The annealing time varies depending upon amount of materials or type of furnace. Generally, the annealing time is between 1.5 to 2.5 hours.

Heating and Cooling Speed

Abrupt heating and cooling must be avoided to prevent any deformation of the iron core. Slow cooling must be applied until it reaches 300~350°C, after that and cooling is permitted.

Furnace Atmosphere

Furnace atmosphere should be controlled to minimize carburization or oxidization which can diminish magnetic properties. Therefore, a pure nitrogen atmosphere is ideal and the dew point of gas should be maintained as low as possible (below 0°C is adequate). The oil used in shearing and punching should be removed completely. Otherwise both sides of piled-up core will be damaged during the annealing process, deteriorating the work capacity.

Surface Condensation in Relation to Humidity and Temperature

■ Reference for rust

Condensed Water on steel surface Graph according to Humidity and Temperature

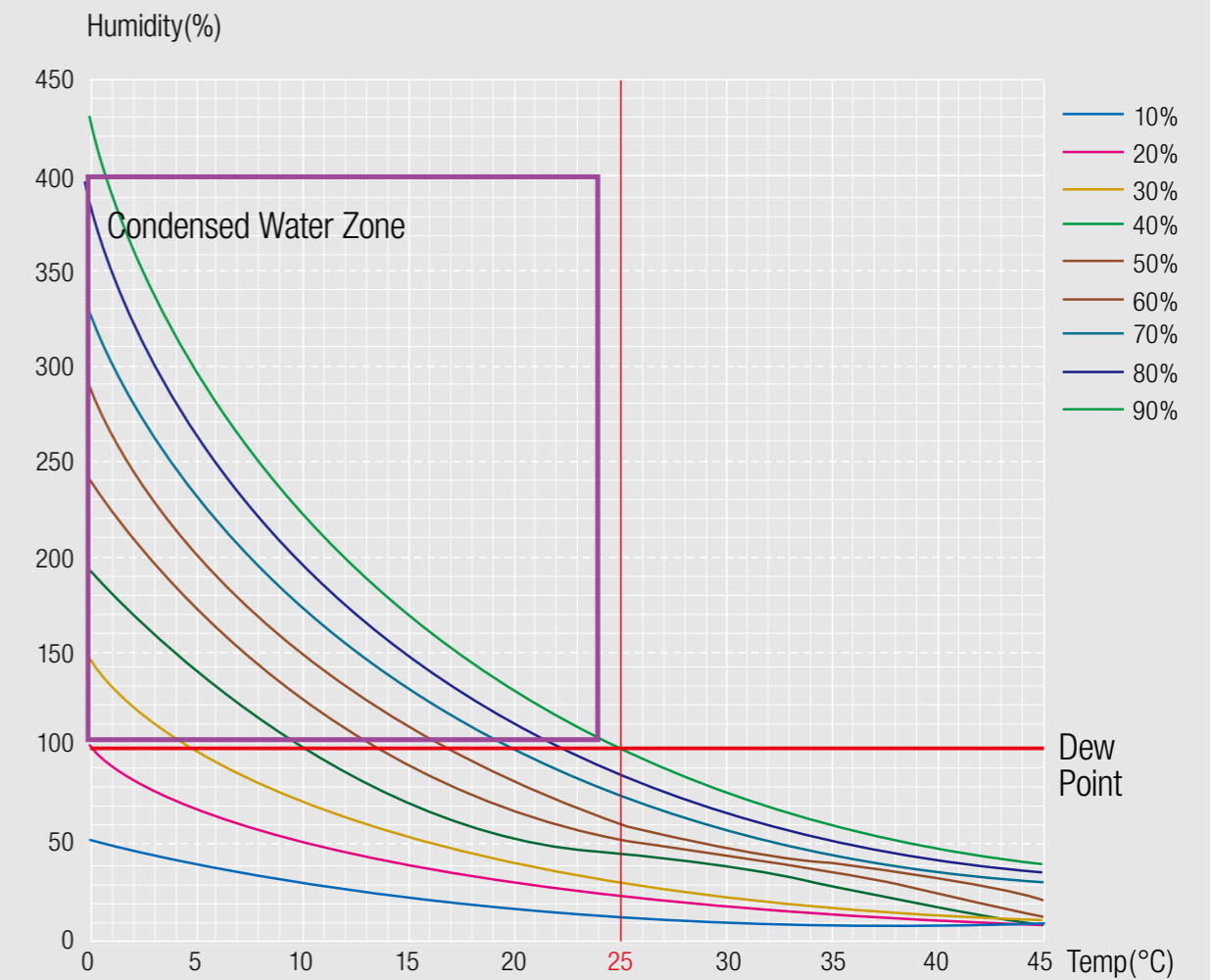

Water is condensed on the steel surface in certain temperature and humidity in store place and steel is likely to get rusty.
Ex) In a place of 25°C, humidity 80%, water is condensed when temp decrease to 22°C.

Relation Among Weight, Outside Diameter And Width Of Coil

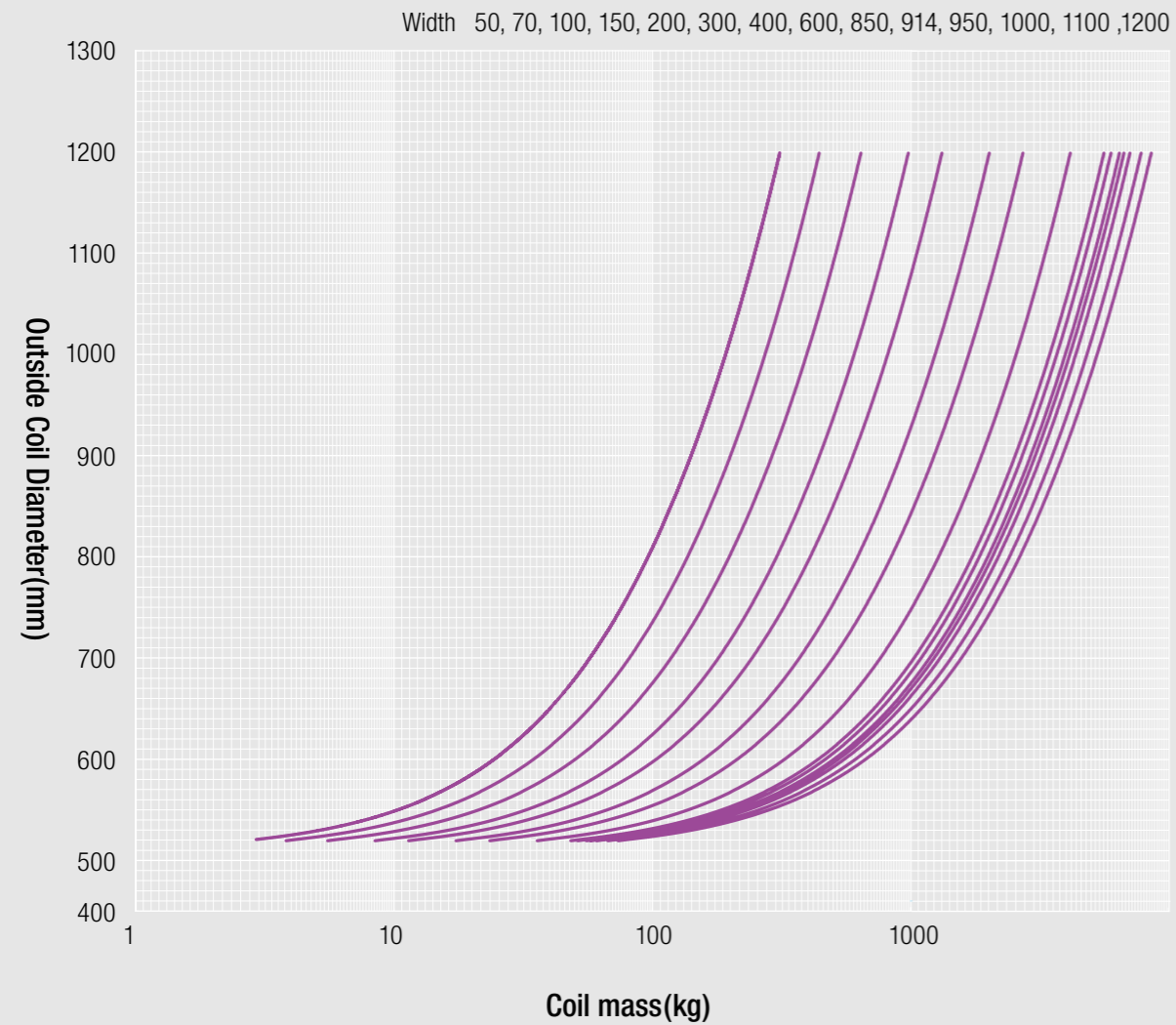

Major International Standards

When ordering, please be sure to consult our latest and check the specifications or standards of products may change.

■ Grain-Oriented Electrical Steel

Thickness mm (in.)	POSCO	JIS C 2553	ASTM	EN10107
	(2006) W/kg 17/50	(2000) W/kg 17/50	(1999) W/kg 17/60	(1995) W/kg 17/50
0.23 (0.0091)	23PHD085 0.85	23R085 0.85	23Q054 1.19	-
	23PH090 0.90	23P090 0.90	-	-
	23PH095 0.95	23P095 0.95	-	-
	23PH100 1.00	23P100 1.00	23P060 1.32	M100-23P 1.00
0.27 (0.0106)	27PHD090 0.90	27R090 0.90	-	-
	27PH095 0.95	-	-	-
	27PH100 1.00	27P100 1.00	-	M103-27P 1.03
	27PH110 1.10	27P110 1.10	27P066 1.46	-
	27PH120 1.20	27G120 1.20	-	-
	27PH130 1.30	27G130 1.30	27H074 1.63	M130-27S 1.30
0.30 (0.0118)	30PH100 1.00	-	-	M105-30P 1.05
	30PH105 1.05	30P105 1.05	-	-
	-	30P105 1.10	-	M111-30P 1.11
	-	30P105 1.20	-	M117-30P 1.17
	30PH130 1.30	30G130 1.30	-	-
	30PH140 1.40	30G140 1.40	30H083 1.83	M140-30S 1.40
0.35 (0.0138)	35PH145 1.45	35G145 1.45	-	-
	35PH155 1.55	35G155 1.55	35H094 2.07	M150-35S 1.50

Note) The core loss of POSCO products is the maximum guarantee value at 1.7T and 50Hz

Major International Standards

■ Non-Oriented Electrical Steel

Thickness mm (in.)	POSCO	JIS C 2552	ASTM	EN10106
	(2006) W/kg 15/50	(2000) W/kg 15/50	(1999) W/kg 15/60	(1995) W/kg 15/50
0.035 (0.0138)	35PN210 2.10	35A210 2.10	-	-
	35PN230 2.30	35A230 2.30	-	M235-35A 2.35
	35PN250 2.50	35A250 2.50	36F145 3.20	M250-35A 2.50
	35PN270 2.70	35A270 2.70	36F155 3.42	M270-35A 2.70
	35PN300 3.00	35A300 3.00	36F175 3.86	M300-35A 3.00
	35PN360 3.60	35A360 3.60	36F205 4.52	-
	35PN440 4.40	35A440 4.40	-	-
0.50 (0.0197)	-	50A230 2.30	-	-
	50PN250 2.50	50A250 2.50	-	M250-50A 2.50
	50PN270 2.70	50A270 2.70	-	M270-50A 2.70
	50PN290 2.90	50A290 2.90	47F165 3.64	M290-50A 2.90
	50PN310 3.10	50A310 3.10	47F180 3.97	M310-50A 3.10
	50PN350 3.50	50A350 3.50	47F200 4.41	M350-50A 3.50
	50PN400 4.00	50A400 4.00	47F210 4.63	M400-50A 4.00
	50PN470 4.70	50A470 4.70	47F240 5.29	M470-50A 4.70
	50PN600 6.00	50A600 6.00	-	M600-50A 6.00
	50PN700 7.00	50A700 7.00	47F400 8.82	M700-50A 7.00
	50PN800 8.00	50A800 8.00	47F450 9.92	M800-50A 8.00
	50PN1000 10.00	50A1000 10.00	-	M1000-50A 10.00
	50PN1300 13.00	50A1300 13.00	-	-

Note) The core loss of POSCO products is the maximum guarantee value at 1.5T and 50Hz

Unit Conversion Tables, The International System of Units(SI)

■ Magnetizing force

	Oersted	A/m	A/in
1 Oersted	1	7.96×10	2.02
1 Ampere per Meter(A/m)	1.256×10^{-2}	1	2.54×10^{-2}
1 Ampere per Inch(A/in)	4.95×10^{-1}	3.94×10	1

■ Magnetic flux density

	Gauss	Tesla	Wb/m ²	Line/in ²
1 Gauss(G)	1	10^{-4}	10^{-4}	6.45
1 Tesla(T)	10^4	1	1	6.45×10^4
1 Weber per Square Meter(Wb/m ²)	10^4	1	1	6.45×10^4
1 Line per Square Inch(Line/in ²)	1.55×10^{-1}	1.55×10^{-5}	1.55×10^{-5}	1

■ Core Loss

	W/kg	W/lb
1 Watt Per Kilogram(W/kg)	1	4.54×10^{-1}
1 Watt Per Pound(W/lb)	2.204	1

Packaging / Marking



Name of outer pack

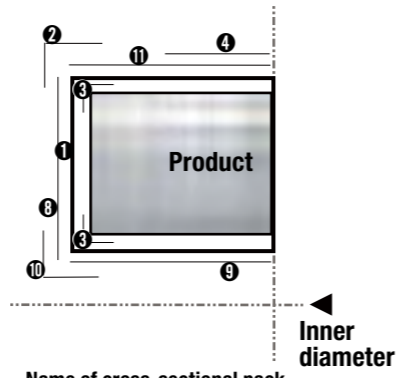

Name of cross-sectional pack

Inner diameter

NO	Name	Material
①	PP VCI WRAP	VINYL
②	OUTER RING	STEEL
③	CORNER WRAP	ANTI-RUST BOARD
④	OUTER PROTECT BOARD	STEEL
⑤	HORIZONTAL BAND	STEEL
⑥	CENTER BAND	PET
⑦	VERTICAL BAND	STEEL
⑧	SIDE BOARD	PLASTIC
⑨	INNER PROTECT BOARD	PLASTIC
⑩	INNER RING	STEEL
⑪	OUTER PROTECT BOARD	ANTI-RUST BOARD

* Packing Type and materials are changeable.

Domestic

ELECTRICAL STEEL COIL **GO**

CUSTOMER: POSCO CUSTOMER
 SPEC: 30PH 105
 SIZE: 0.30 X 1000 X C
 NET WT: 3500 kg
 GR. WT: 3520 kg
 GRADE: 1

PROF. NO. **0001234567010**
EAN0001

DATE: 2014.00.00
 HEAT NO: Y12345

posco Pohang Works
 Made in Korea

DCC3A EAN0001
 XXXYYZZ XX Z

Export

ELECTRICAL STEEL COIL **NO**

CUSTOMER: POSCO CUSTOMER
 SPEC: JIS C2552 50A600
 SIZE: 0.50 X 1200 X C
 NET WT: 3500 kg
 GR. WT: 3520 kg
 GRADE: 1

PROF. NO. **CBB0001**
CBB0001

FINAL DESTINATION: XX PORT
 PROF. NO. 0001234567010
 PO. NO. 12345

DATE: 2014.00.00
 HEAT NO: Y12345

posco Pohang Works
 Made in Korea



DCC3A CBB0001
 XXXYYZZ XX Z

ELECTRICAL STEEL

Copyright © 2014 by POSCO
 All rights reserved

Contact Us

POSCO Center 440, Teheran-ro,
 Gangnam-gu, Seoul, Korea
 Global Technical Center
 TEL 82-2-3457-0690
 FAX 82-2-3457-1980



Headquarters

6261, Donghaean-ro, Nam-gu, Pohang-si,
Gyeongsangbuk-do 790-300, Korea

TEL 82-54-220-0114

FAX 82-54-220-6000

Seoul Office

POSCO Center, 440, Teheran-ro,
Gangnam-gu, Seoul 135-777, Korea

TEL 82-2-3457-0114

FAX 82-2-3457-6000

Pohang Works

6261, Donghaean-ro, Nam-gu, Pohang-si,
Gyeongsangbuk-do 790-785, Korea

TEL 82-54-220-0114

FAX 82-54-220-6000

Gwangyang Works

20-26, Pokposarang-gil, Gwangyang-si,
Jeollanam-do 545-711, Korea

TEL 82-61-790-0114

FAX 82-61-790-7000



www.posco.com

www.steel-n.com